

DRIVER ASSISTANT FOR DROWSINESS AND ALCOHOL EFFECT DETECTION

Pushpa P¹, Dhonvan Srinu², P Bhulaxmi³, V. V. Ramana Rao⁴

^{1,2}Assistant professor, Dept of Electronics and Communication Engineering,

³Lecturer, Dept of Electronics and Communication Engineering,

⁴Associate Professor, Dept of Electronics and Communication Engineering

^{1,4}St. Martin's Engineering College, Hyderabad-500100, ²Marri Laxman Reddy Institute of technology and management, ³Kamala Nehru Polytechnic College for Women, Hyderabad-500001

ABSTRACT

Human errors are causing an increase in the number of deaths and injuries in traffic accidents every year. Drowsiness is the second largest cause of traffic accidents, after drinking. People are aware of the dangers of drinking and driving, but they are unaware of the dangers of tiredness because there are no equipment to measure driver drowsiness. One of the key technical issues in the vehicle business is the development of safety measures to prevent intoxicated and drowsy driving. Drunk or drowsy driving is a major cause of traffic accidents, especially in today's society. Driving while tired has a higher crash risk than driving while attentive. As a result, adopting assistive devices to check a driver's state of attentiveness can be extremely beneficial in avoiding accidents. The goal of this study is to detect driver tiredness using a visual characteristics technique, as well as to detect intoxicated drivers using an alcohol sensor. When a motorist loses concentration while driving, it affects the driver's reaction time and steering behaviour. Driver drowsiness can result in a variety of physical and financial damages; one method of detecting tiredness is to observe the driver while driving; if the driver is not concentrating on driving, the driver is alerted with an alarm sound. In the existing system humans need to monitor manually for a driver. There are more chances of accidents. Drawbacks of existing system are manual monitoring and inaccurate. In the proposed system we can reduce the most accident. Alcohol sensor and IR sensors will be used for easy detection of driver condition. Advantages of proposed system are, it can be operated automatically and alarm is provided.

Keywords: *Alcohol sensor, IR sensors, Arduino IDE and DC Motors.*

I. Introduction

The major goal of this paper is to see if building a driver intoxication detection system based on a dynamic analysis of a subject's pupillary light reflex is feasible (PLR). This automatic response is extensively used in the medical profession to detect a number of disorders, and the efficacy of such a method to show an impaired status owing to alcohol misuse is reviewed in this research. The test

method entails applying a light stimulus to one of the subject's eyes and recording the dynamics of constriction in both eyes; for extracting pupil size profiles from video sequences, a two-step methodology is described, in which the first stage involves performing an iris/pupil search within the image, and the second stage involves cropping the image to perform pupil detection on a smaller image to improve time efficiency. The undesired pupil dynamics arising in the PLR are defined and evaluated; a spontaneous oscillation of the pupil diameter is observed in the range $[0, 2]$ Hz and the accommodation reflex causes pupil constriction of about 10% of the iris diameter. A database of pupillary light responses is acquired on different subjects in baseline condition and after alcohol consumption, and for each one, a first-order model is identified. A set of features is introduced to compare the two populations of responses and is used to design a support vector machine classifier to discriminate between “Sober” and “Drunk” states.

To perform any application in the embedded system we require microprocessor and micro controller. In the microprocessor an external memory is connected which increases the size of the microprocessor and multiple operations are being performed by the microprocessor but whereas in the microprocessor the memory is inbuilt and also, we can use this controller only for the specific applications where the speed is increased so most probably micro-controllers are used in the different applications in the embedded systems rather than microprocessor.

An embedded system can be defined as a computing device that does a specific focused job. Appliances such as the air-conditioner, VCD player, DVD player, printer, fax machine, mobile phone etc. are examples of embedded systems. Each of these appliances will have a processor and special hardware to meet the specific requirement of the application along with the embedded software that is executed by the processor for meeting that specific requirement. The embedded software is also called “firm ware”. The desktop/laptop computer is a general-purpose computer. You can use it for a variety of applications such as playing games, word processing, accounting, software development and so on. Application Areas are consumer appliances: office automation, industrial automation, medical electronics, computer networking, telecommunications, wireless technologies, insemination, security, finance.

II. SYSTEM DESCRIPTION

POWER SUPPLY

The power supply section is the section which provide +5V for the components to work. IC LM7805 is used for providing a constant power of +5V.

The ac voltage, typically 220V, is connected to a transformer, which steps down that ac voltage down to the level of the desired dc output. A diode rectifier then provides a full-wave rectified voltage that is initially

filtered by a simple capacitor filter to produce a dc voltage. This resulting dc voltage usually has some ripple or ac voltage variation.

A regulator circuit removes the ripples and also retains the same dc value even if the input dc voltage varies, or the load connected to the output dc voltage changes. This voltage regulation is usually obtained using one of the popular voltage regulator IC units.

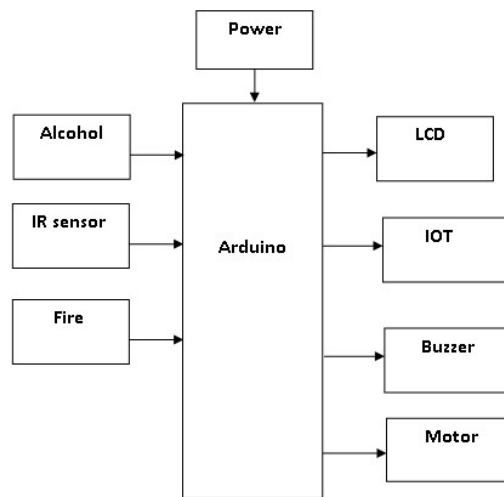

Block Diagram

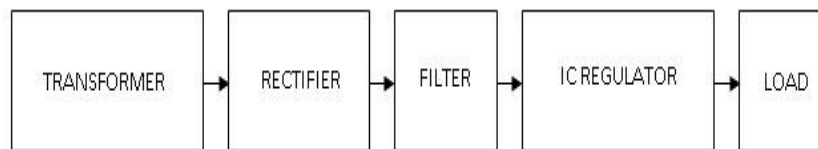

Block Diagram of Power Supply

Transformer

Transformers convert AC electricity from one voltage to another with little loss of power.

Transformers work only with AC and this is one of the reasons why mains electricity is AC. Step-up transformers increase voltage, step-down transformers reduce voltage. Most power supplies use a step-down transformer to reduce the dangerously high mains voltage (230V in India) to a safer low voltage.

The input coil is called the primary and the output coil is called the secondary. There is no electrical connection between the two coils; instead they are linked by an alternating magnetic field created in the soft-iron core of the transformer. Transformers waste very little power so the power out is (almost) equal to the power in. Note that as voltage is stepped down current is stepped up. The transformer will step down the power supply

voltage (0-230V) to (0- 6V) level. Then the secondary of the potential transformer will be connected to the bridge rectifier, which is constructed with the help of PN junction diodes. The advantages of using bridge rectifier are it will give peak voltage output as DC.

Rectifier

There are several ways of connecting diodes to make a rectifier to convert AC to DC. The bridge rectifier is the most important and it produces full-wave varying DC. A full-wave rectifier can also be made from just two diodes if a center-tap transformer is used, but this method is rarely used now that diodes are cheaper. A single diode can be used as a rectifier but it only uses the positive (+) parts of the AC wave to produce half-wave varying DC

Bridge Rectifier

When four diodes are connected as shown in figure, the circuit is called as bridge rectifier. The input to the circuit is applied to the diagonally opposite corners of the network, and the output is taken from the remaining two corners. Let us assume that the transformer is working properly and there is a positive potential, at point A and a negative potential at point B. the positive potential at point A will forward bias D3 and reverse bias D4.

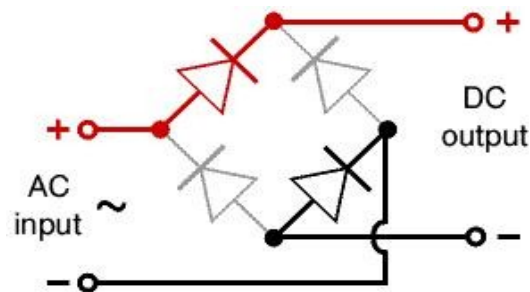

Bridge Rectifier

The negative potential at point B will forward bias D1 and reverse D2. At this time D3 and D1 are forward biased and will allow current flow to pass through them; D4 and D2 are reverse biased and will block current flow. One advantage of a bridge rectifier over a conventional full-wave rectifier is that with a given transformer the bridge rectifier produces a voltage output that is nearly twice that of the conventional full-wave circuit.

- i. The main advantage of this bridge circuit is that it does not require a special centre tapped transformer, thereby reducing its size and cost.
- ii. The single secondary winding is connected to one side of the diode bridge network and the load to the other side as shown below.
- iii. The result is still a pulsating direct current but with double the frequency.

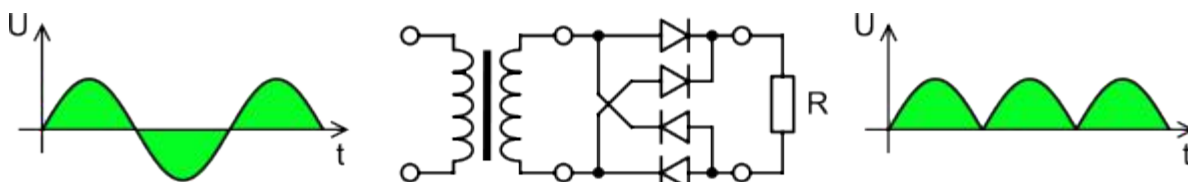

Output Waveform of DC

Smoothing is performed by a large value electrolytic capacitor connected across the DC supply to act as a reservoir, supplying current to the output when the varying DC voltage from the rectifier is

falling. The capacitor charges quickly near the peak of the varying DC, and then discharges as it supplies current to the output. Voltage regulators comprise a class of widely used IC's. Regulator IC units contain the circuitry for reference source, comparator amplifier, control device, and overload protection all in a single IC. IC units provide regulation of either a fixed positive voltage, a fixed negative voltage, or an adjustably set voltage. The regulators can be selected for operation with load currents from hundreds of milli amperes to tens of amperes, corresponding to power ratings from milli watts to Tens of watts.

A fixed three-terminal voltage regulator has an unregulated dc input voltage, V_i , applied to one input terminal, a regulated dc output voltage, V_o , from a second terminal, with the third terminal connected to ground. The series 78 regulators provide fixed positive regulated voltages from 5 to 24 volts. Similarly, the series 79 regulators provide fixed negative regulated voltages from 5 to 24 volts. Voltage regulator IC's are available with fixed (typically 5, 12 and 15V) or variable output voltages. They are also rated by the maximum current they can pass. Negative voltage regulators are available, mainly for use in dual supplies. Most regulators include some automatic protection from excessive current ('overload protection') and overheating ('thermal protection'). Many of the fixed voltage regulator IC's has 3 leads and look like power transistors, such as the 7805 +5V 1Amp regulator. They include a hole for attaching a heat sink if necessary.

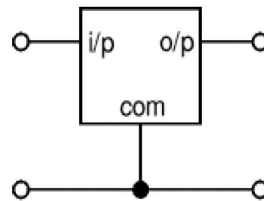

Regulator

A Microcontroller (or MCU) is a computer-on-a-chip used to control electronic devices. It is a type of microprocessor emphasizing self-sufficiency and cost-effectiveness, in contrast to a general-purpose microprocessor (the kind used in a PC). A typical microcontroller contains all the memory and interfaces needed for a simple application, whereas a general purpose microprocessor requires additional chips to provide these functions.

A microcontroller is a single integrated circuit with the following key features:

- central processing unit - ranging from small and simple 8-bit processors to sophisticated 32- or 64-bit processors
 - input/output interfaces such as serial ports
 - RAM for data storage
 - ROM, EEPROM or Flash memory for program storage
 - clock generator - often an oscillator for a quartz timing crystal, resonator or RC circuit
- Microcontrollers are inside many kinds of electronic equipment (see embedded system). They

are the vast majority of all processor chips sold? Over 50% are "simple" controllers, and another 20% are more specialized digital signal processors (DSPs) (ref?). A typical home in a developed country is likely to have only

one or two general-purpose microprocessors but somewhere between one and two dozen microcontrollers. A typical mid-range vehicle has as many as 50 or more microcontrollers. They can also be found in almost any electrical device: washing machines, microwave ovens, telephones etc.

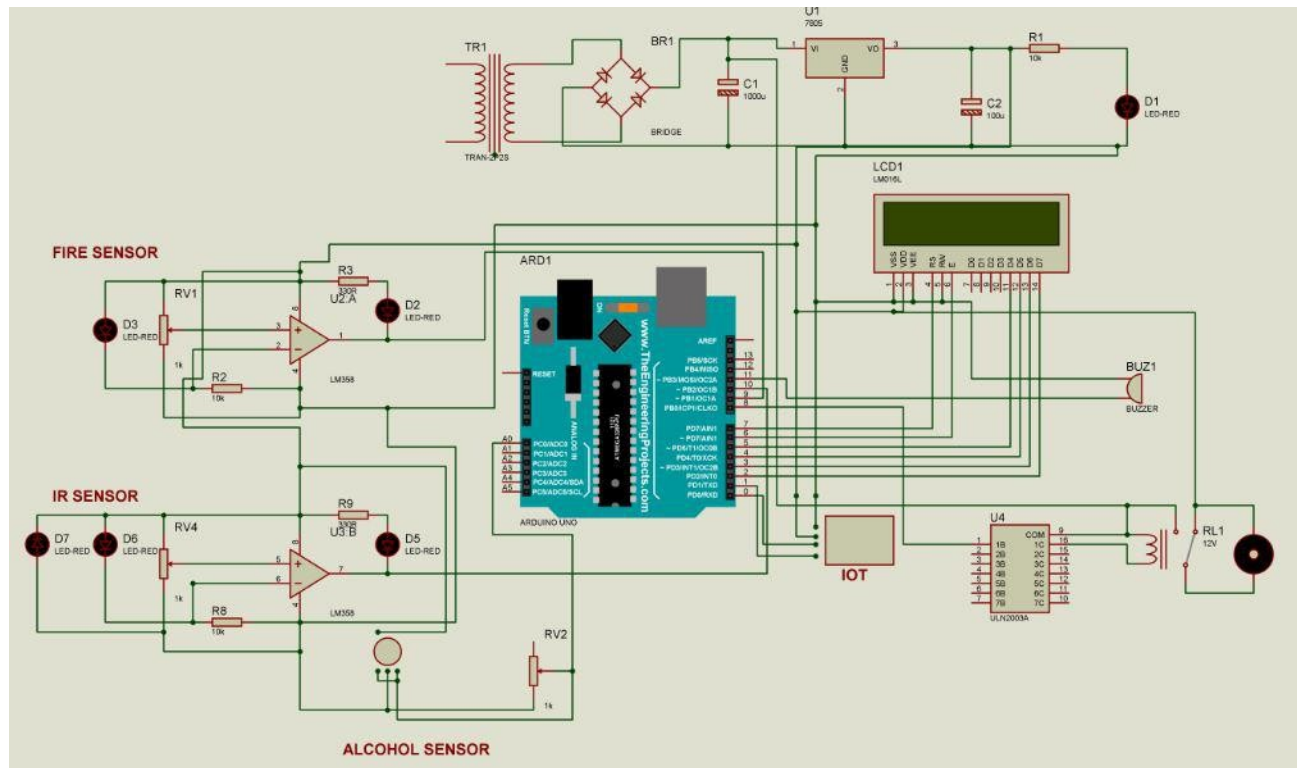

Arduino/genuine Uno is a microcontroller board based on the atmega328p (data sheet). It has 14 digital input/output pins (of which 6 can be used as pwm outputs), 6 analog inputs, a 16 MHz quartz crystal, a USB connection, a power jack, an icsp header and a reset button. It contains everything needed to support the microcontroller; simply connect it to a computer with a USB cable or power it with a ac-to- dc adapter or battery to get started. You can tinker with your UNO without worrying too much about doing something wrong, worst case scenario you can replace the chip for a few dollars and start over again.

"UNO" means one in italian and was chosen to mark the release of arduino software (IDE) 1.0. The uno board and version 1.0 of arduino software (IDE) were the reference versions of arduino, now evolved to newer releases. The uno board is the first in a series of USB arduino boards, and the reference model for the arduino platform; for an extensive list of current, past or outdated boards see the arduino index of boards.

III. RESULTS AND CONCLUSION

The pupillary light reflex serves as a valuable indicator of autonomic nervous system function. Moreover, measurement of the reflex using dynamic pupillometry provides a quantitative, non-invasive tool, which may aid the diagnosis and clinical management of a wide range of clinical conditions, varying from neurodegenerative disease to exposure to toxic chemicals.

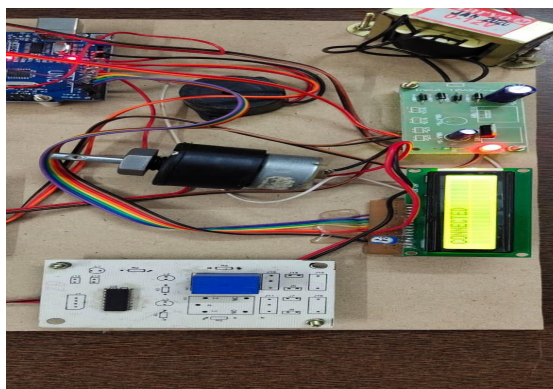
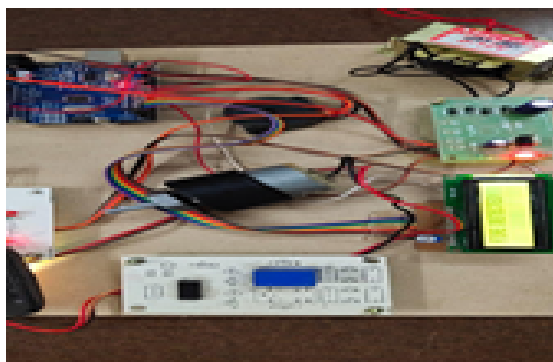

IV REFERENCES:

1. Hirata, Y.; Yamaji, K.; Sakai, H.; Usui, S. Function of the pupil in vision and information capacity of retinal image. *Syst. Comput. Jpn.* 2003, 34, 48–57. [CrossRef]
2. McDougal, D.H.; Gamlin, P.D. Autonomic control of the eye. *Compr. Physiol.* 2015, 5, 439–473. [CrossRef] [PubMed]
3. Girkin, C. Evaluation of the pupillary light response as an objective measure of visual function. *Ophthalmol. Clin. N. Am.* 2003, 16, 143–153. [CrossRef]
4. Loewen Feld, I.E. *The Pupil: Anatomy, Physiology, and Clinical Applications*, 2nd ed.; Butterworth-

Heinemann: Boston, MA, USA, 1999.

5. Winn, B.; Whitaker, D.; Elliott, D.B.; Phillips, N.J. Factors affecting light-adapted pupil size in normal human subjects. *Investig. Ophthalmol. Vis. Sci.* 1994, 35, 1132–1137.
6. Adhikari, P.; Pearson, C.A.; Anderson, A.M.; Zele, A.J.; Feigl, B. Effect of age and refractive error on the melanopsin mediated post-illumination pupil response (PIPR). *Sci. Rep.* 2015, 5, 17610. [CrossRef] [PubMed]
7. Ellis, C.J. The pupillary light reflex in normal subjects. *Br. J. Ophthalmol.* 1981, 65, 754–759. [CrossRef] [PubMed]
8. Lowenstein, O.; Loewenfeld, I.E. The sleep-waking cycle and pupillary activity. *Ann. N. Y. Acad. Sci.* 1964, 117, 142–156. [CrossRef] [PubMed]
9. Bergamin, O.; Kardon, R.H. Latency of the pupil light reflex: Sample rate, stimulus intensity, and variation in normal subjects. *Investig. Ophthalmol. Vis. Sci.* 2003, 44, 1546–1554. [CrossRef]
10. Barbur, J. Learning from the pupil: Studies of basic mechanisms and clinical applications. In *the Visual Neurosciences*; MIT: Cambridge, MA, USA, 2004; pp. 641–656.